

TABLE OF CONTENTS:

INTRODUCTION:	2
DESIGN, FUNCTION & OPERATION	2
FIGURE 1: MODEL 3011L - SHUT-OFF CONDITION	2
FIGURE 2: MODEL 3011H - FLOWING CONDITION	2
FIGURE 3: TYPICAL TANK INSTALLATION	3
TABLE 1: MODEL 3011/3041 SPECIFICATIONS	3
GENERAL SAFETY INSTRUCTIONS	4
SAFETY WARNINGS	4
INSPECTION AND INSTALLATION	5
MODEL SELECTION AND PRESSURE SETTING	6
TABLE 2 – SET PRESSURE RANGES	6
TABLE 3 – SPRING SELECTION	7
TABLE 4 – FLOW CAPACITY SETTING	8
TABLE 5 – ORIFICE SLEEVE POSITION	8
BLANKETING THE TANK	8
TROUBLESHOOTING GUIDE	9
PREVENTIVE MAINTENANCE	9
RECOMMENDED SPARE PARTS	9
TABLE 6 – SOFT GOODS KITS	9
DISASSEMBLY	10
FIGURE 4: SPRING CHAMBER ASSEMBLY	10
FIGURE 5: PISTON/BODY ASSEMBLY	10
FIGURE 6: EXPLODED PISTON ASSEMBLY	11
FIGURE 7: ACTUATOR LINKAGE ASSEMBLY	11
ASSEMBLY	11
TABLE 7 – RECOMMENDED BOLT TORQUE	12
FIGURE 8: ORIFICE SLEEVE ORIENTATION	12
FIGURE 9: EXPLODED PISTON ASSEMBLY	12
FIGURE 10: PISTON/BODY ASSEMBLY	12
TESTING AND SETTING PROCEDURE	13
FIGURE 11: TEST SET-UP	13
FIGURE 12: CROSS SECTIONAL ASSEMBLY	14
BILL OF MATERIAL	15
HOW TO ORDER	20
PRODUCT LIMITED WARRANTY	20

INTRODUCTION:

The blanket gas regulator is one of the principal components typically installed on a storage tank to protect the tank and its contents. It is a precision regulator that is capable of maintaining a very low gas pressure (1/2" WC minimum) in the tank by controlling the flow of a high pressure (200 PSI maximum) blanketing gas. It maintains a positive tank pressure when fluid is pumped out or as fluid temperature decreases.

Typically nitrogen or another compatible gas is used to suppress the tank product vapors. This reduces losses due to product evaporation and prevents atmospheric contaminants, including moisture, from entering the tank, preventing tank corrosion and product contamination. The use of an inert blanketing gas minimizes air pollution due to leakage or emergency venting.

In addition to the blanketing regulator, a tank must be protected from structural damage by pressure and vacuum relief valves. A typical tank installation is shown in Figure 3, which includes the regulator, a pressure vacuum relief valve and an emergency pressure relief valve. Groth Corporation manufactures all of these devices.

The regulator must be maintained by a knowledgeable valve technician. It should only be assembled under clean conditions, preferably in a shop environment. Carefully read and understand this manual before attempting to adjust set pressure or flow capacity, or repair the regulator.

For information not contained in this manual, please contact:

Groth Corporation
13650 N. Promenade Blvd
Stafford, TX 77477
281-295-6800 (Phone)
281-295-6995 (Fax)

DESIGN, FUNCTION & OPERATION

The Groth Model 3011L, 3011H, 3011HP, 3041L, 3041H, & 3041HP Regulators are high capacity, spring operated, diaphragm type, balanced piston regulators, designed for tank blanketing applications.

The regulator controls the flow of blanketing gas to the vapor space in the storage tank. When the internal pressure of the tank is at or above set pressure, the diaphragm force exceeds the spring force and the regulator is shut off bubble tight. When the tank pressure falls below the set point, the spring force opens the regulator and blanket gas flows into the tank (See Figures 1 and 2).

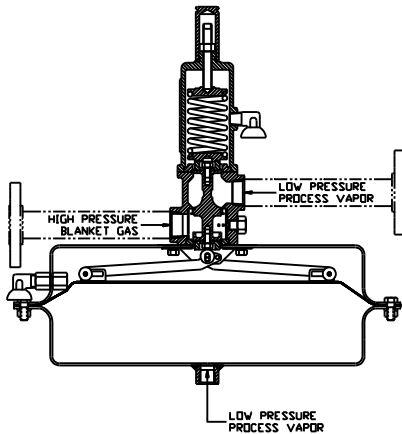

FIGURE 1: MODEL 3011L - SHUT-OFF CONDITION

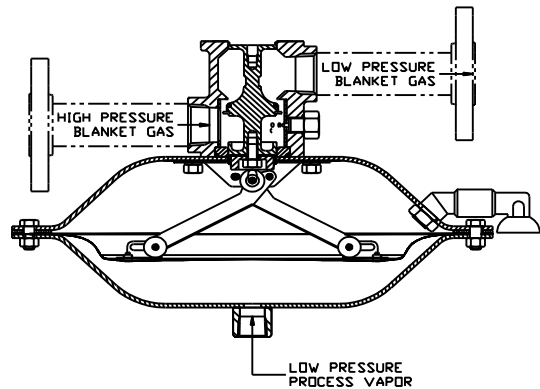

FIGURE 2: MODEL 3011H - FLOWING CONDITION

The regulator must be sized to provide sufficient blanket gas to prevent the loss of tank pressure due to liquid discharge or decreased ambient temperature. Table 4 lists the maximum flow capacity of the regulator for various blanketing gases. Actual system flow will depend on supply system piping, tank connection piping and position of the internal orifice sleeve. Set pressure is the pressure at which the regulator begins flowing when tank pressure is decreasing and stops flowing when tank pressure is increasing.

This manual is intended to provide recommended procedures and practices for installation, operation, and maintenance of the Groth MODEL 3011L, 3011H, 3011HP, 3041L, 3041H and 3041HP Regulators. Any standard procedures and practices developed for a specific plant or process should supersede this manual. While this manual cannot cover all possible contingencies, following these guidelines should provide safe, reliable regulator performance.

Note: Throughout this manual, the item numbers are listed in [] after the part description. These item numbers refer to the Bill of Materials (Page 14) and various drawings of the regulator and its sub-assemblies (Figures 4 through 10). While the size and appearance of the actuators differs between the 3011L and 3011H, the item identification and description of the components are identical.

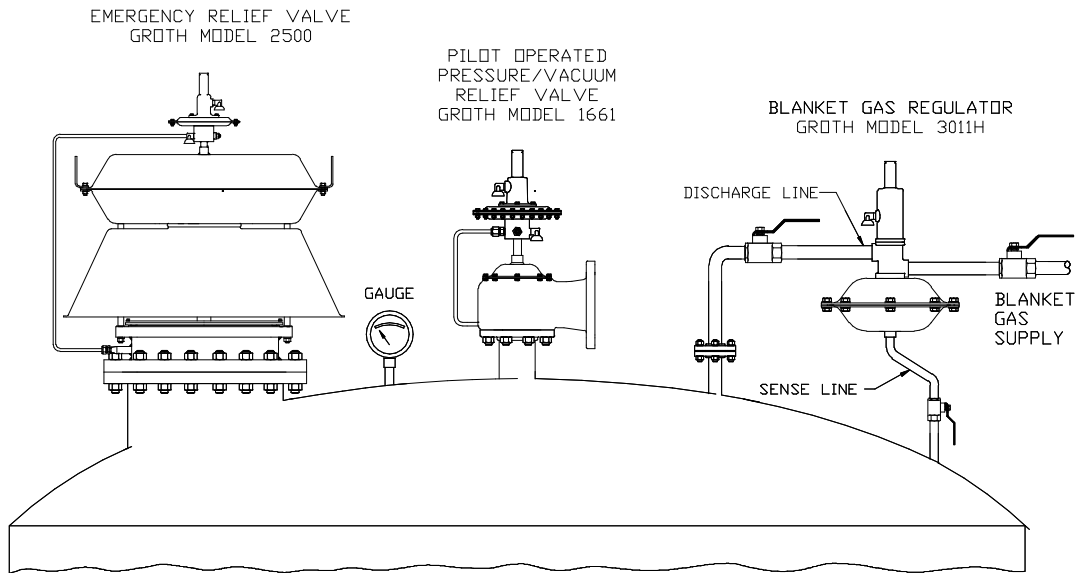

FIGURE 3: TYPICAL TANK INSTALLATION

TABLE 1: MODEL 3011/3041 SPECIFICATIONS

SIZE	1/2"	1"
Inlet/Outlet connection size	1/2"	1"
Maximum supply pressure	200 PSI	200 PSI
Actuator Housing MAWP	8 PSI	8 PSI

GENERAL SAFETY INSTRUCTIONS

This section is intended as an overview of safety guidelines that should be followed during the installation, operation and maintenance of the Groth model 3011L, & 3041L, 3011H & 3041H, 3011HP & 3041HP Blanket Gas Regulators. To understand the context of these warnings and instructions, read and understand this complete manual.

The blanket gas regulator is one of the principal protection devices typically installed on a product storage tank. It is a precision regulator that is designed to maintain a positive pressure on the tank. This will prevent product loss or contamination from atmospheric air when pumping liquid out or when the stored fluid cools.

The blanket gas regulator should not be used as a substitute for a vacuum relief valve. An interruption in the blanket gas supply could cause tank failure.

SAFETY WARNINGS

IN THE EVENT OF AN ACTUATOR OR PISTON DIAPHRAGM FAILURE, THE REGULATOR WILL FAIL IN THE OPEN POSITION. GAS FLOW WILL NOT BE SHUT OFF. EMERGENCY AND OR PRESSURE/VACUUM RELIEF VALVES MUST BE SIZED TO INCLUDE BLANKET GAS REGULATOR CAPACITY IN ADDITION TO NORMAL AND EMERGENCY VENTING REQUIREMENTS.

IN THE EVENT OF BLANKET GAS SUPPLY FAILURE, THE REGULATOR WILL NOT PROTECT THE TANK FROM AN EXCESS VACUUM CONDITION. BLANKET GAS SUPPLY FAILURE SHOULD BE CONSIDERED IN THE SIZING, SELECTION AND SETTING OF PRESSURE/VACUUM RELIEF VALVES.

BLANKET GAS REGULATOR FLOW CAPACITY IS BASED ON A KNOWN SUPPLY PRESSURE AND A PROPERLY SIZED GAS DISTRIBUTION SYSTEM.

ALL SUPPLY PIPING MUST BE FREE OF WELD SLAG AND OTHER DEBRIS BEFORE INSTALLING THE BLANKET GAS REGULATOR. IF WELD SLAG OR DEBRIS FLOWS THROUGH THE REGULATOR THERE IS A HIGH POTENTIAL FOR SEATING SURFACE AND O-RING DAMAGE. THIS TYPE OF DAMAGE WILL CAUSE THE REGULATOR TO CONSTANTLY FLOW BLANKETING GAS TO THE TANK. TO PREVENT DAMAGE FROM WELD SLAG OR DEBRIS CONSIDER INSTALLING AN UPSTREAM FILTER OR STRAINER. AN ENGINEERING ANALYSIS MUST BE PERFORMED TO EVALUATE THE EFFECT THESE DEVICES MAY HAVE ON THE BLANKET GAS REGULATOR FLOW CAPACITY.

THE REGULATOR IS NORMALLY FACTORY SET AT THE DESIRED SET PRESSURE. THE SPRING RANGE IS STAMPED ON THE NAMEPLATE. DO NOT ATTEMPT TO RE-ADJUST THE SET PRESSURE BEYOND THE LIMITS SPECIFIED IN TABLE 3.

THE REGULATOR IS TO BE CONNECTED TO THE TANK OR VESSEL WITH A MINIMUM 0.31" ID TUBING SENSE LINE. THIS LINE MUST BE KEPT OPEN AND UNOBSTRUCTED TO ENSURE THAT THE REGULATOR SENSES THE ACTUAL TANK PRESSURE. LONG SENSE LINES MAY REQUIRE A LARGER DIAMETER AND CARE MUST BE TAKEN TO ASSURE THAT THE LINE IS SELF-DRAINING. FOR SOME APPLICATIONS, A NITROGEN PURGE MAY BE REQUIRED TO ENSURE THAT THIS LINE REMAINS OPEN. CONSULT FACTORY FOR RECOMMENDATIONS.

DO NOT ATTEMPT TO REMOVE THE REGULATOR FROM THE LINE OR PERFORM FIELD REPAIRS IN LINE WITHOUT FIRST ISOLATING THE REGULATOR FROM BOTH THE TANK AND THE SUPPLY GAS LINE. BLEED ALL PRESSURE BEFORE REMOVING THE SPRING BONNET OR THE FLOW ORIFICE LOCKING SCREW, OR OPENING UP THE ACTUATOR HOUSINGS.

NOTE THE ORIFICE SLEEVE POSITION WHEN DISASSEMBLING THE REGULATOR. IT WAS FACTORY SET ACCORDING TO THE FLOW REQUIREMENTS LISTED ON THE ORDER AND MUST BE RE-INSTALLED IN THE SAME POSITION TO ENSURE THE CORRECT FLOW.

THE REGULATOR BODY AND ACTUATOR HOUSING ARE EXPOSED TO PROCESS VAPORS. OBSERVE ALL SAFETY PRECAUTIONS AS SPECIFIED ON THE MATERIAL SAFETY DATA SHEET FOR THE PRODUCTS THAT ARE IN THE TANK.

THE VENTS ON THE SPRING BONNET AND ACTUATOR HOUSING MUST BE CLEAN AND OPEN TO THE ATMOSPHERE AND SHOULD BE INSPECTED PERIODICALLY.

THE RECOMMENDED SET PRESSURE RANGE OF THE REGULATOR SPRING IS STAMPED ON THE NAMEPLATE. NEVER ADJUST A SPRING FOR A SET PRESSURE BEYOND ITS DESIGN RANGE AS SPECIFIED IN TABLE 3. EXCEEDING THE SPRING UPPER LIMIT MAY COMPRESS THE SPRING TO ITS SOLID HEIGHT, AND PREVENT THE REGULATOR FROM CLOSING. SETTING IT BELOW THE LOWER LIMIT MAY PREVENT THE REGULATOR FROM OPENING FULLY AT THE REQUIRED PRESSURE.

INSPECTION AND INSTALLATION

The regulator is packaged and supported to prevent damage or contamination in shipping. It should be similarly protected during subsequent handling and storage. Always keep all ports plugged to prevent intrusion of foreign materials. Before installation, visually inspect the unit. If there are indications of physical damage or internal contamination, the regulator must be disassembled, cleaned and inspected before installation. If factory set, the spring adjustment cap and the orifice selector locking screw must be secure. Report any shipping damage to your carrier.

If the regulator is stored in an uncontrolled environment, some condensation may accumulate in the actuator housing due to temperature fluctuations. Invert the regulator and drain all condensation through the vents.

The available regulator inlet and outlet connections are 1/2" NPT (F), 1/2" 150# RF ANSI, Quick Disconnect Fittings, or 1" sanitary fitting for the 1/2" size and 1" NPT (F) or 1" 150# RF ANSI flange for the 1" size. The regulator must be installed leveled. The direction of the flow is marked on the body. It is to be installed in accordance with accepted piping practices. Full bore block valves should be installed upstream and downstream of the regulator and in the sense line to allow it to be removed from the system for maintenance.

Blanket Gas Regulator flow capacity is based on a known supply pressure at the regulator inlet port, and choked flow (discharge piping pressure drop less than half of the supply pressure). Consult factory for capacity data if supply and/or discharge piping do not meet these criteria.

The regulator is to be connected to the tank or vessel with a minimum 0.31" ID tubing sense line. This line must be kept open and unobstructed to ensure that the regulator "senses" the actual tank pressure. Long sense lines may require a larger diameter and care must be taken to assure that the line is self-draining. For some applications, a nitrogen purge may be required to ensure that this line remains open. Consult the factory for recommendations for remote installations or vapors that may cause line obstructions.

MODEL SELECTION AND PRESSURE SETTING

Model selection is based on a combination of set pressure and supply pressure as shown in Table 2.

The regulator may be set at the factory or on the tank or vessel when initially introducing blanketing gas. A pressure gauge (or manometer) is required to indicate the tank pressure.

WARNING: When adjusting the regulator on the tank, always be sure that the sense line is open and unobstructed. Monitor the tank pressure accurately.

Set pressure is adjusted by removing the spring chamber cap [3] and rotating the adjustment screw [11]. Back-off the hex jam nut [27] and turn the screw clockwise (tighten) to increase set pressure. The model 3011L, 3011H & 3011HP regulators cover a range of set pressures from 0.5" WC to 1.99 psig. The model 3041L, 3041H & 3041HP regulators cover a range of set pressures from 0.5" WC to 1.99 psig. Table 2 shows standard set pressure ranges.

The set pressure range with the original spring is stamped on the valve nameplate. The regulator will not function properly if the setting is outside this range. If higher or lower settings are required, the necessary components can be obtained from Groth Corporation. They must be installed according to instructions in the maintenance section of this manual.

TABLE 2 – SET PRESSURE RANGES

1/2" 3011 SERIES				
	Supply Pressure psig / (barg)			
Pressure Setting INWC (mbarg)	5 to 50 (0.34 to 3.4)	>50 to 100 (3.4 to 6.9)	>100 to 150 (6.9 to 10.3)	>150 to 200 (10.3 to 13.8)
0.5 to <1.0 (1.2 to 2.5)				3011L
1.0 to <1.5 (2.5 to 3.7)	3011H			
1.5 to <2.0 (3.7 to 5.0)				
2.0 to 6.5 (5.0 to 16)				

1/2" 3041 SERIES				
	Supply Pressure psig / (barg)			
Vacuum Setting INWC (mbarg)	5 to 50 (0.34 to 3.4)	>50 to 100 (3.4 to 6.9)	>100 to 150 (6.9 to 10.3)	>150 to 200 (10.3 to 13.8)
0.5 to <1.0 (1.2 to 2.5)				3041L
1.0 to <1.5 (2.5 to 3.7)	3041H			
1.5 to <2.0 (3.7 to 5.0)				
2.0 to 6.5 (5.0 to 16)				

1" 3011 SERIES				
	Supply Pressure psig / (barg)			
Pressure Setting INWC (mbarg)	5 to 50 (0.34 to 3.4)	>50 to 100 (3.4 to 6.9)	>100 to 150 (6.9 to 10.3)	>150 to 200 (10.3 to 13.8)
0.5 to <1.0 (1.2 to 2.5)			3011L	
1.0 to <1.5 (2.5 to 3.7)				3011L
1.5 to <2.0 (3.7 to 5.0)	3011H			
2.0 to <6.5 (5.0 to 16)	3011H			
6.5 to <2 psig (16 to 140)	3011HP			

1" 3041 SERIES				
	Supply Pressure psig / (barg)			
Vacuum Setting INWC (mbarg)	5 to 50 (0.34 to 3.4)	>50 to 100 (3.4 to 6.9)	>100 to 150 (6.9 to 10.3)	>150 to 200 (10.3 to 13.8)
0.5 to <1.0 (1.2 to 2.5)			3041L	
1.0 to <1.5 (2.5 to 3.7)				3041L
1.5 to <2.0 (3.7 to 5.0)	3041H			
2.0 to <6.5 (5.0 to 16)	3041H			
6.5 to <2 psig (16 to 140)	3041HP			

TABLE 3 – SPRING SELECTION

SPRING RANGES 1" SIZE

Model No.	Max Supply (psig barg)	Min Setting (in. water mbarg)	Max Setting (in. water mbarg)	Spring Range
3011L/ (3041L)	200	0.5	≤0.8	3
	13.8	1.2	2.0	
	200	0.8	≤1.0	4
	13.8	2.0	2.5	
	200	1.0	≤2.0	5
	13.8	2.5	5.0	

3011H/ (3041H)	50	0.5	≤1.0	1
	3.4	1.2	2.5	
	100	1.0	≤1.5	2
	6.9	2.5	3.7	
	150	1.5	≤2.0	3
	10.3	3.7	5.0	
	200	2.0	≤3.5	4
	13.8	5.0	8.7	
	200	3.5	≤6.5	5
	13.8	8.7	16	

SPRING RANGES 1/2" SIZE

Model No.	Max Supply (psig barg)	Min Setting (in. water mbarg)	Max Setting (in. water mbarg)	Spring Range
3011L/ (3041L)	200	0.5	≤0.8	2
	13.8	1.2	2.0	
	200	0.8	≤1.0	3
	13.8	2.0	2.5	

3011H/ (3041H)	50	0.5	≤0.7	1
	3.4	1.2	1.7	
	200	0.7	≤1.7	2
	13.8	1.7	4.2	
	200	1.7	≤3.0	3
	13.8	4.2	7.5	
	200	3.0	≤4.5	4
	13.8	7.5	11.2	
	200	4.5	≤6.5	5
	13.8	11.2	16	

Note: When spring ranges overlap, select the lighter spring

Model No.	Max Supply (psig barg)	Min Setting (in. water mbarg)	Max Setting (in. water mbarg)	Spring Range
3011HP/ (3041HP)	200	6.5	≤11	2
	13.8	16.2	27.4	
	200	11.0	≤18.5	3
	13.8	27.6	46.1	
	200	18.5	≤27.6	4
	13.8	46.3	68.7	
	200	27.6 psig	≤1.37 psig	5
	13.8	69.0	94.5	
	200	1.37 psig	2.0 psig	6
	13.8	95.2	138	

TABLE 4 – FLOW CAPACITY SETTING

Table 4 shows flow capacity for a regulator set at 100% full open. Unless otherwise specified, the orifice selector sleeve [12] is factory set at the 100% full open position.

FLOW CAPACITY (SCFH) *									
Supply Pressure		Carbon Dioxide		Nitrogen		Natural Gas 0.55 S.G.		AIR	
PSIG	BARG	1/2"	1"	1/2"	1"	1/2"	1"	1/2"	1"
5	0.34	2160	4600	2810	5800	3660	7400	2800	5700
10	0.69	3250	7100	4230	8800	5490	11300	4190	8700
15	1.03	4370	9200	5690	11500	7390	14600	5630	11300
20	1.38	5130	11200	6680	14000	8680	17900	6610	13800
30	2.07	6630	15100	8630	18900	11210	24000	8540	18600
40	2.76	8140	18800	10590	23600	13760	30000	10480	23200
50	3.45	9650	22500	12560	28200	16320	35800	12430	27700
60	4.14	11160	26000	14520	32600	18860	41500	14370	32100
80	5.52	14180	33000	18440	41300	23950	52600	18250	40700
100	6.89	17200	40000	22370	50100	29060	63700	22140	49300
120	8.27	20210	47000	26290	58800	34150	74800	26020	57900
140	9.65	23230	53900	30220	67500	39250	85900	29910	66500
160	11	26240	60900	34140	76300	44340	97000	33790	75100
180	12.4	29260	67900	38060	85000	49440	108100	37680	83700
200	13.8	32280	74900	41990	93700	54540	119200	41560	92300

* Orifice sleeve installed in 100% flow capacity position.

NOTE: Flow capacity values are in SCFH. For NCMH, multiply the listed capacities by 0.029

If reduced capacity is specified on an order, the sleeve is set at the appropriate restriction. Actual capacity at any other position can be calculated by multiplying the capacity value from Table 4 for a specific pressure by the decimal value from Table 5.

TABLE 5 – ORIFICE SLEEVE POSITION

ORIFICE SLEEVE POSITION							
1	2	3	4	5	6	7	8
1.0	0.75	0.50	0.25	0.20	0.15	0.10	0.05
FLOW CAPACITY MULTIPLIER							

1/2" Models are only available with positions 1, 2, 3, and 4

BLANKETING THE TANK

Before installing a new or replacement regulator, the tank pressure must be below the desired set pressure so the regulator setting can be verified. Sequentially open the block valves in the following order: (1) Sense Line, (2) Regulator Discharge Line and (3) Regulator Supply (See Figure 3).

If the regulator was set at the factory, blanket gas will begin to flow immediately. The tank pressure must be monitored closely to verify that the gas flow shuts off at the set pressure.

If the regulator was not set at the factory, make sure that the adjusting screw [11] is backed out as far as possible (no spring compression). When the blanket gas supply valve is turned on, there will be no flow, unless the tank pressure is very low. Now slowly turn the adjusting screw to increase tank pressure and the gas will begin to flow. The tank pressure can be increased as gradually as desired until the correct pressure setting is attained. When tank pressure is reached, back out adjusting screw, if necessary, until gas flow stops.

WARNING: In the event of an actuator diaphragm [42] or piston diaphragm [36] failure, the regulator will fail in the open position. Gas flow will NOT be shut off. Emergency and or pressure/vacuum relief valves must be sized to include blanket gas regulator capacity in addition to normal and emergency venting requirements.

TROUBLESHOOTING GUIDE

PROBLEM	INSPECTION	SUGGESTED CORRECTIVE ACTION
Gas flowing at tank pressure above specified set point.	Flow indicator in blanket gas line.	Damaged seat, O-Ring or diaphragm or pressure setting too high. If original pressure setting has not been disturbed, remove regulator and repair.
Gas not flowing at tank pressure below specified set point.	Flow indicator in blanket gas line.	Damaged spring or pressure setting too low. If original pressure setting has not been disturbed, remove regulator and repair.
Gas leaking from upper vent or bonnet flange.	Soap bubble test and joining surface or emission indication near the regulator.	Damaged upper piston diaphragm. Remove regulator from tank and replace diaphragm. Diaphragm installed incorrectly. Reinforcement fabric must be opposite to pressure (see page 12).
Blanket gas leaking from lower body seal or actuator housing vent.	Soap bubble test at joining surface or emission indication near the regulator.	Damaged lower piston diaphragm. Remove regulator from tank and replace diaphragm. Diaphragm installed incorrectly. Reinforcement fabric must be opposite to pressure (see page 12).
Process vapor leaking from actuator housing flange or vent.	Soap bubble test at joining surface or emission indication near the regulator.	Damaged actuator diaphragm or loose housing bolts. Tighten bolts or remove regulator from tank and replace diaphragm.
Tank pressure above or below specified operating range during pump out or pump in.	Observe tank pressure indicator during pumping operations.	Excess or insufficient blanket gas flow. Check flow orifice orientation. Refer to Tables 4 & 5 for flow capacity data. Check gas supply pressure. Remove and repair regulator if other conditions are correct.
Tank pressure or vacuum exceeds vent settings during pump out or pump in.	Observe tank pressure indicator during pumping operations.	Pressure/vacuum relief vent not functioning or not sized properly. Inspect and repair or replace as necessary.

PREVENTIVE MAINTENANCE

Periodically, while in service, examine the regulator for leakage at bolted connections, adjusting screws, etc. Test for blanket gas or process vapor emissions from vent caps.

RECOMMENDED SPARE PARTS

The following spare parts should be stocked for maintenance purposes:

- Spring [34]; See Table 3 for the correct part number.
 - Vent [24]; part number 10064003
 - Soft Goods Kit; See Table 6 for the correct part number.
- When ordering spare parts, include model and serial number of regulator, pressure setting, and required material for soft goods.

TABLE 6 – SOFT GOODS KITS

1/2" BGR		
Elastomer	3011L	3011H
Buna-N	KS3011L05B	KS3011H05B
FFKM	KS3011L05C	KS3011H05C
EPDM	KS3011L05E	KS3011H05E
FKM	KS3011L05V	KS3011H05V

1" BGR		
Elastomer	3011L	3011H
Buna-N	KS3011L01B	KS3011H01B
FFKM	KS3011L01C	KS3011H01C
EPDM	KS3011L01E	KS3011H01E
FKM	KS3011L01V	KS3011H01V

DISASSEMBLY

WARNING: Before removing the regulator from the tank for service, block and vent supply, discharge and sense lines. Never attempt to remove the regulator from the line, or to remove the spring bonnet or orifice sleeve locking screw if the regulator is pressurized.

All service on the regulator may be performed with the following common tools:

- 7/16" – 9/16" box end wrenches
- 1/4" or 3/8" open end wrench*
- 1/2" socket wrench
- Adjustable wrench
- 1/8" Hex wrench

*Wrench must be 8" long for 1/2" BGR or 12" long for 1" BGR flanged units.

Thread a 1/2" pipe nipple into the sense port on the lower actuator housing [5]. Use a vise and clamp onto the pipe nipple. This makes a good holding fixture and provides some degree of rotation while working on the regulator.

Remove the spring chamber cap [3] and loosen the hex jam nut [27]. Turn the adjustment screw [11] counterclockwise to completely relax the spring [34].

Remove the hex bolt [28] and lock washers [29]. Remove the spring chamber [2]. Remove the upper spring button [10], the spring [34], the lower spring button [10] and then the bonnet adapter ring [9].

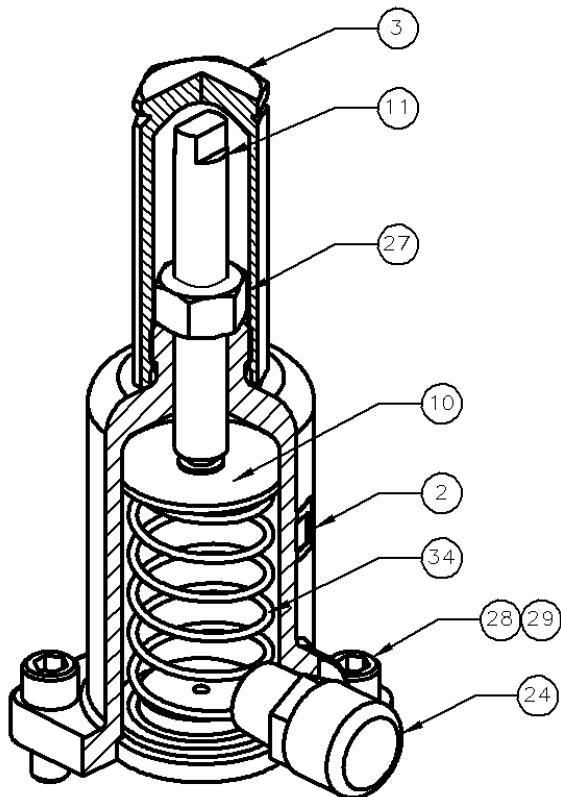

FIGURE 4: SPRING CHAMBER ASSEMBLY

WARNING: Diaphragm actuator housing and regulator body are exposed to the process vapor(s). Observe all standard safety precautions as specified on Material Safety Data Sheets for the product(s) that are in the tank. These precautions apply both during removal of the regulator from the tank and while repairing it.

Use a 3/8" (1/4" for 1/2" BGR) open-end wrench and insert it through the inlet port to hold the piston [6] at the wrench flats. Remove hex bolt [31] for 1" BGR models or button head cap screws [30] for 1/2" BGR models while holding onto the piston. Be careful not to let the piston rotate during removal of the hex bolt. The piston diaphragms [36] can be torn if care is not taken. Remove the upper diaphragm retainer [8] and the upper piston diaphragm [36].

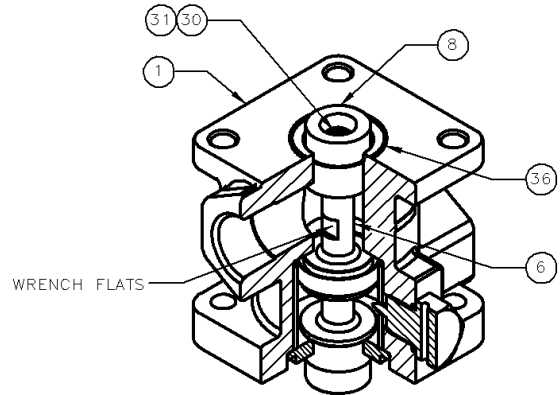

FIGURE 5: PISTON/BODY ASSEMBLY

Remove the body/actuator assembly from the vise with the pipe nipple connected. Invert the assembly and clamp the body [1] in the vise.

Remove the hex nuts, lock washers, and hex bolts [33, 32 & 31]. Remove the lower actuator housing [5], the actuator gasket [35] and the actuator diaphragm [42].

Insert a 1/2" socket wrench through the holes in the actuator support plate [15] and remove the (2) hex bolts [28] and lock washers [29] that retain the actuator linkage assembly. Remove the linkage assembly and set it aside. Remove the other (2) hex bolts and the upper actuator housing [4].

Remove the piston guide ring [14], the guide ring O-Ring [40] and the piston assembly from the body. Remove the hex bolt [31] or button head cap screw [30], O-Ring retainer [7] and piston diaphragm [36] from the piston. Remove the stop lift ring [47] (1" size only) the retaining ring [38] and the piston O-Ring [37]. Use care to prevent permanently expanding the metal rings or scratching the surface of the piston.

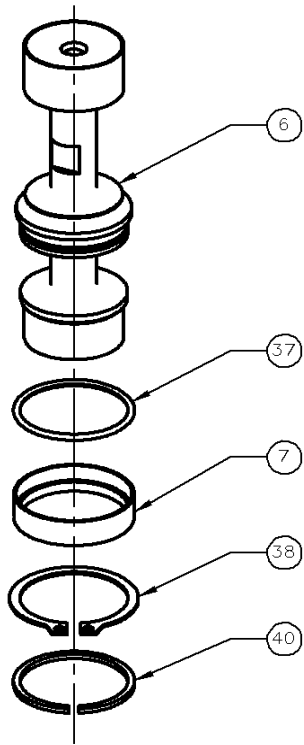

FIGURE 6: EXPLODED PISTON ASSEMBLY

Refer to "FLOW CAPACITY SETTING" and warnings on Page 7 before removing the orifice selector sleeve [12] from the body. Back the orifice lock screw [13] completely out of the body. Before removing the orifice selector sleeve, make note of its position by looking through the screw port. There will be a number stenciled on the sleeve indicating the position of the sleeve. Note this number for re-assembly. Refer to Tables 4 & 5 to determine flow capacity of the regulator at a specific orifice sleeve position.

HP MODELS HAVE PISTON PIN

Clean and inspect the sleeve, body cavity and seat. Polish or lap the seat if required to obtain a sharp but smooth seating edge for the O-Ring.

All components should be examined for damage or wear. Replace all diaphragms, O-Rings and gaskets. Prior to reassembly, make sure all components are clean.

Inspect the actuator linkage assembly. The assembly is riveted and should not be disassembled. All components should be straight and flat. All rollers and pins must be free to rotate and slide as the support plate moves vertically.

ASSEMBLY

Before assembly note the following material and tool recommendations:

Diaphragms, O-Rings, gasket, vents and spring as listed in Table 6.

Lubricants & Thread Sealants

- A. Molykote No. 33 Light grease
- B. Dry Moly Spray
- C. Fluoropolymer tape

Assembly Tools

- A. 7/16" – 9/16" box end wrenches
- B. 1/4" or 3/8" open end wrench*
- C. 1/2" socket wrench
- D. Adjustable wrench
- E. 1/8" hex wrench

*Wrench must be 8" long for 1/2" BGR or 12" long for 1" BGR flanged units

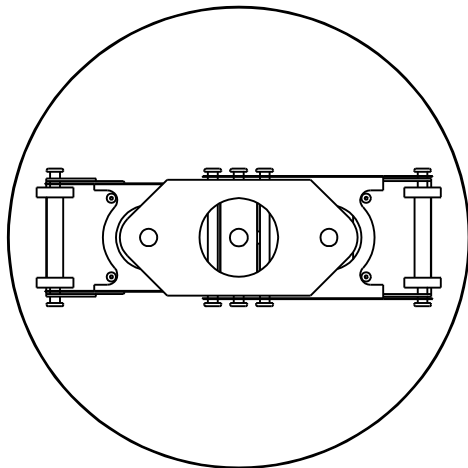

FIGURE 7: ACTUATOR LINKAGE ASSEMBLY FOR 3011 L / H & 3041 L / H

TABLE 7 – RECOMMENDED BOLT TORQUE

TABLE 7						
RECOMMENDED BOLT TORQUE [FT. - LB.]						
Bolt Size	10-32	1/4"	5/16"	3/8"	7/16"	1/2"
Torque	3-5	6	11	20	32	44

All screw threads and static O-Rings should be lightly greased with grease. Lubricate the piston OD at both ends and the spring adjusting screw with Dry Moly spray. If the greases listed above are not compatible with the tank vapors, use equivalent lubricants for that media. All pipe threads are to be wrapped with Fluoropolymer tape or suitable pipe thread sealant applied sparingly.

Before installing the orifice selector sleeve, read the section entitled "FLOW CAPACITY SETTING" and related warnings on page 7. Install the orifice selector sleeve [12] into the regulator body. Observe the sleeve position locking hole by looking in the locking screw hole in the body. The hole in the sleeve should be exactly centered in the screw hole. If the holes do not line up exactly, invert the sleeve and reinstall. The position indicating numbers will also be seen through the screw hole.

These numbers indicate % open and flow capacity according to Tables 4 and 5. Make sure that the sleeve position is on the same number as when disassembled, or on the number that provides the specified flow requirements.

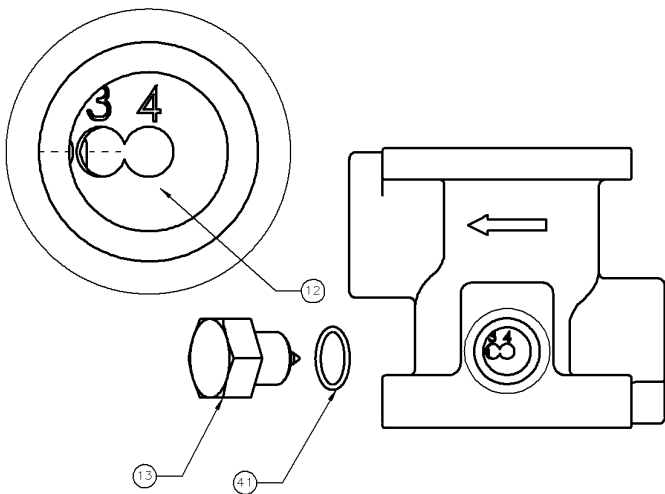

FIGURE 8: ORIFICE SLEEVE ORIENTATION

Grease the locking screw O-Ring [41] and slip it over the screw threads. Thread the orifice lock screw [13] into the body, finger tight, until the point enters the sleeve and the head seats onto the O-Ring. Then wrench tighten the head firmly against the body, compressing the O-Ring.

Note: Damage to the sleeve will occur if force is applied with the point of the locking screw.

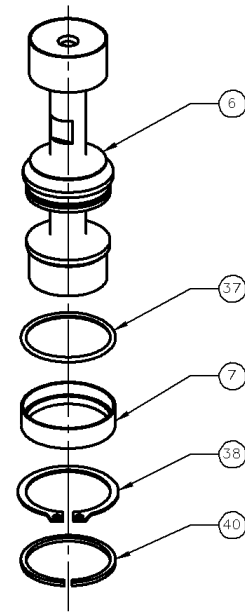

FIGURE 9: EXPLODED PISTON ASSEMBLY

Assemble the piston sub-assembly according to Figure 9. Install the piston O-Ring [37] from the top end of the piston. Do not roll the piston O-Ring, but stretch it just enough to clear the piston diameter. When installing the O-Ring retainer [7], retaining ring [38] and lift stop ring [47] (1" models only) expand the rings just enough to clear the piston without scratching the piston or permanently deforming the rings.

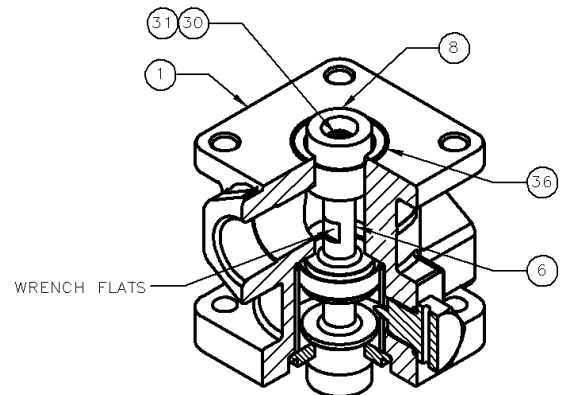

FIGURE 10: PISTON/BODY ASSEMBLY

Slide the piston guide ring [14] over the lower end of the piston and let it rest on the lift stop. Attach the lower piston diaphragm [36] to the piston [6] with the diaphragm retainer [8] and hex bolt [31] for 1" or button head cap screws [30] for 1/2".

Note: Make sure that the diaphragm reinforcing fabric is facing away from the piston. This is essential to develop the pressure rating of the diaphragm.

Secure the body in a vise with the bottom surface facing upward and the inlet port accessible (See Figure 10). Spray the piston sub-assembly with Dry Moly spray and insert it into the body. Install the guide ring O-Ring [40].

Inspect and clean all diaphragm, gasket and seating surfaces before assembling the actuator housing. Position the upper actuator housing [4] on the body and secure with (2) hex bolts [28] & lock washers [29] positioned 180° apart. Torque the two bolts per Table 7. The body should be oriented such that the outlet port aligns with the housing vent hole. Measure the stroke of the piston. The stroke must be a minimum of 0.180" for 1" BGR models and 0.150" for 1/2" BGR models. Then position the actuator linkage assembly into the housing and secure with the other (2) bolts.

WARNING: For 1/2" 3011H Models, install spacer [39] between the actuator housing and linkage assembly.

Apply PTFE sealant tape around the inside hole pattern of the upper actuator housing [4]. Position the actuator diaphragm [42], the actuator gasket [35] and the lower actuator housing [5] and insert hex bolts [31] hex nuts [33] and lock washers [32]. Tighten uniformly in an alternating pattern; refer to Table 7 for recommended torque.

WARNING: Replace bonnet vent or actuator housing vent [24] if damaged or restricted. A plugged housing vent could prevent the regulator from closing. This could cause an over-pressure condition in the tank. A plugged bonnet vent would prevent the release of supply pressure from the bonnet. This could cause personal injury when disassembling.

Invert the assembly in the vise. Install the upper piston diaphragm [36], diaphragm retainer [8] and hex bolt [31] for 1" or button head cap screw bolt [30] for 1/2". Hold piston with appropriate size wrench through inlet port while tightening bolt. Install the bonnet adapter ring [9], spring [34], spring buttons [10] and spring chamber [2]. Attach bonnet to body with hex bolts [28] and lock washers [29] for 1" or socket head cap screws [43] and lock washers [29] for 1/2". Tighten bolts uniformly; refer to Table 7 for recommended torque.

Thread set pressure adjusting screw [11] into bonnet until it engages the upper spring button. Replace hex jam nut [27] and cap [3].

TESTING AND SETTING PROCEDURE

1.0) Equipment

- 1.1) A high pressure air (or inert gas) supply system capable of maintaining a regulated supply pressure of 0-300 PSI.
- 1.2) A low pressure air (gas) supply system capable of maintaining sense pressure at 1/2" WC to 10 PSI. Pressure may be controlled by a regulator or needle valve and a small accumulator. If a needle valve is used, it will require frequent adjustment because the regulator consumes a significant volume of air when operating.
- 1.3) A means of indicating or measuring air flow with a capacity of approximately 30 SCFH.
- 1.4) A means of soap bubble shell testing the assembly.

2.0) Test Procedure and Acceptance Criteria

- 2.1) Connect the high pressure air supply to the regulator inlet port. (See figure 3)
- 2.2) Connect the low pressure air supply to the regulator sense port. (See figure 3)
- 2.3) Connect a reduced size manual shut-off valve to the outlet port. (See figure 3 – Discharge line)

- 2.4) Connect a small diameter hose or plastic tube to the inlet of the flow indicator or flow meter. Use a hand held port cover to attach the flow meter to the regulator outlet port. Never connect the flow meter

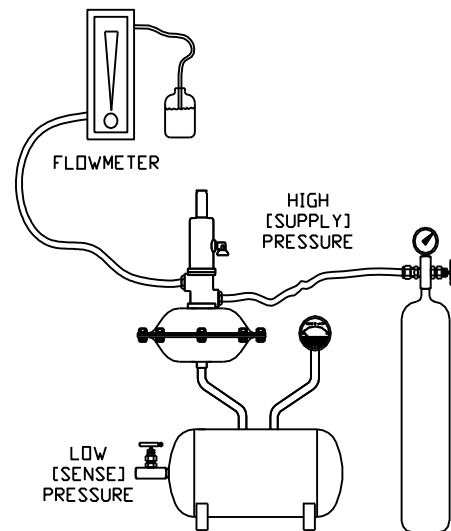

rigidly to the regulator unless the flow meter is rated for full air supply pressure.

FIGURE 11: TEST SET-UP

- 2.5) Connect a small diameter hose or plastic tube to the outlet of the flow indicating device so the end may be immersed in a container of water.
 - 2.6) Close the outlet valve and set the supply air pressure to the maximum available, but not greater than 300 PSI. Soap bubble test the entire assembly at this pressure. Open the outlet valve and reduce the supply until a minimum audible flow is observed.
 - 2.7) Adjust the sense pressure to the specified regulator set pressure. Adjust the adjustment screw [11] to shut off (no audible flow). Now increase the sense pressure to 2 times the specified set pressure or 1.5 times the specified tank MAWP, whichever is greater. Soap bubble test the actuator housing.
 - 2.8) Increase the supply pressure to the specified system pressure (100 PSI if not specified).
 - 2.9) Slowly decrease the sense pressure and adjust the adjustment screw until the air flow is 5-15 SCFH at the specified setting. Lock the adjusting screw at this setting.
 - 2.10) While immersing the outlet tube in water, increase the sense pressure until the regulator is bubble tight. If this pressure exceeds the greater of 10% or 0.5" WC above set pressure, examine the seat and O-Ring. Do not adjust the regulator screw to improve bubble tightness.
- 3.0) Test Report Data**
- 3.1) The following data should be recorded for future reference:

- Model, Tag & Serial numbers
- Test media
- Body & Actuator shell test pressure

- Supply pressure
- Set pressure
- Bubble tight pressure

FIGURE 12: CROSS SECTIONAL ASSEMBLY

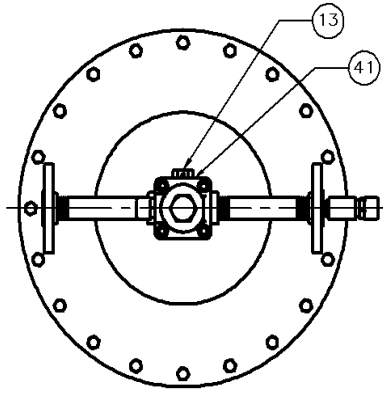

TOP VIEW
(SCREW/ORIFICE LOCKING DETAIL)

TYPE	FLANGE
STANDARD	1/2" FPT
OPTIONAL	1/2" 150# ANSI RF
OPTIONAL	1/2" 300# ANSI RF
OPTIONAL	1" 150# ANSI RF
OPTIONAL	1" SF

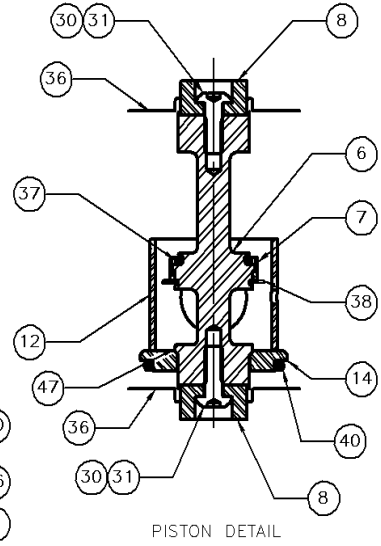

PISTON DETAIL

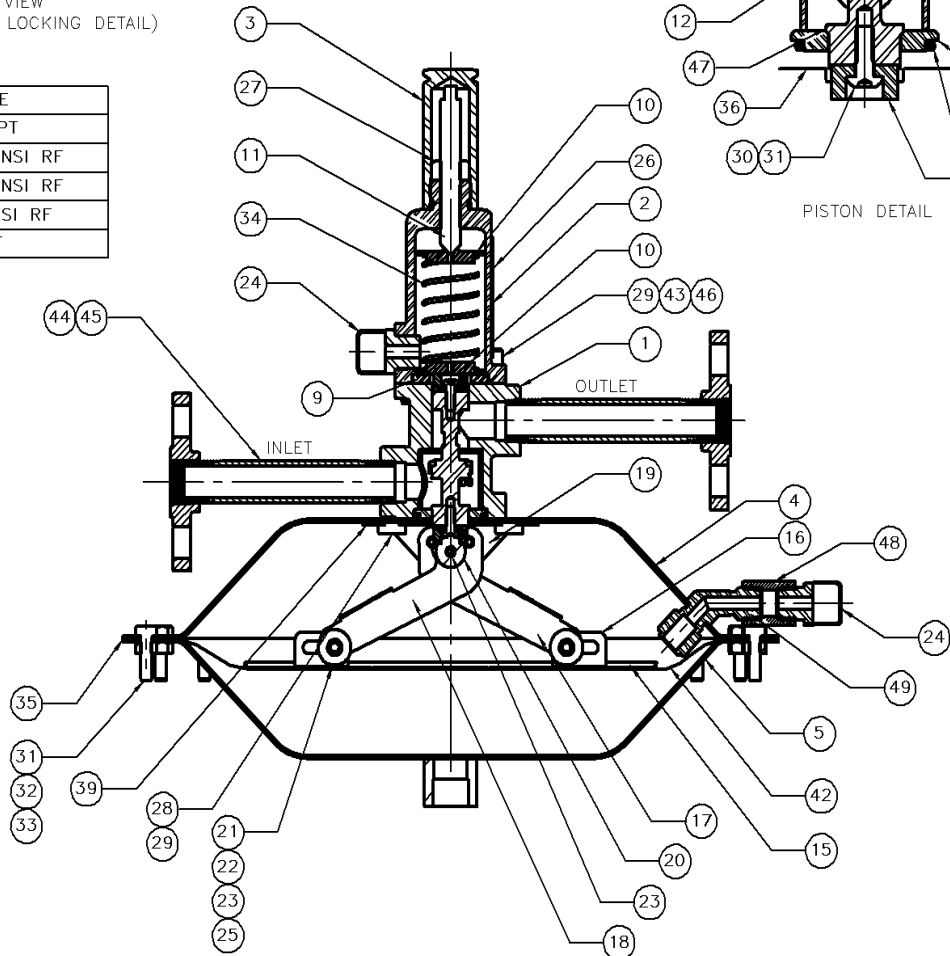

MODEL 3011L, 3011H, 3041L AND 3041H
BILL OF MATERIAL

ITEM	DESCRIPTION	STANDARD MATERIALS OF CONSTRUCTION
1	BODY	CF-8M (316 SS)
2	SPRING CHAMBER	CF-8M (316 SS)
3	CAP, SPRING CHAMBER	316 SS
4	ACTUATOR HOUSING UPPER	316 SS
5	ACTUATOR HOUSING LOWER	316 SS
6	PISTON	316 SS
7	O-RING RETAINER	316 SS
8	RETAINER, DIAPHRAGM	316 SS
9	ADAPTER, BONNET	316 SS
10	SPRING BUTTON	316 SS
11	ADJUSTMENT SCREW	304 SS
12	ORIFICE SELECTOR SLEEVE	316 SS
13	SCREW, ORIFICE LOCK	316 SS
14	GUIDE- PISTON RING	316 SS
15	ACTUATOR SUPPORT PLATE	316 SS
16	BRACKET SUPPORT PLATE	316 SS
17	ARM, ACTUATOR INNER	316 SS
18	ARM, ACTUATOR OUTER	316 SS
19	BRACKET, ACTUATOR HOUSING	316 SS
20	ROLLER, ACTUATOR	NYLON
21	ROLLER, ACTUATOR	NYLON
22	SPACER, ROLLER	TYGON
23	PIN, ACTUATOR	316 SS
24	VENT	ZINC PLATED STEEL
25	RIVET	316 SS
26	NAMEPLATE	316 SS
27	NUT, HEX JAM	SS
28	BOLT, HEX	SS
29	WASHER, LOCK	SS
30	BOLT, BUTTON HEAD CAPSCREW (1/2" Models Only)	SS
31	BOLT, HEX	SS
32	WASHER, LOCK	SS
33	NUT, HEX	SS
34	SPRING	316 SS
35	* GASKET, ACTUATOR (1)	FEP
36	* DIAPHRAGM, PISTON (2)	FKM
37	* O-RING, PISTON (2)	FKM
38	RING, RETAINING	SS
39	SPACER, BRACKET ACT. HOUSING (1/2" 3011H Model Only)	316 SS
40	* O-RING, GUIDE RING (2)	FKM
41	* O-RING, LOCKING SCREW (2)	FKM
42	* DIAPHRAGM, ACTUATOR (1)	FEP
43	CAPSCREW, SOCKET HEAD (1/2" Models Only)	316 SS
44	NIPPLE, PIPE (OPTIONAL)	
45	FLANGE, RF (OPTIONAL)	316 SS
46	HEX BOLT (1" Models Only)	316 SS
47	STOP LIFT (1" Models Only)	316 SS
48	** CONNECTOR FEMALE	316 SS
49	** 45° MALE ELBOW	316 SS

* SPARE PARTS

** 1/2" 3011L/3041L and 1" 3011H/3041H

(1) ELASTOMERS ALSO AVAILABLE IN EPR, BUNA-N & FFKM.

MODEL 3011HP
BLANKET GAS REGULATOR
STANDARD

SEE TOP VIEW FOR ORIENTATION

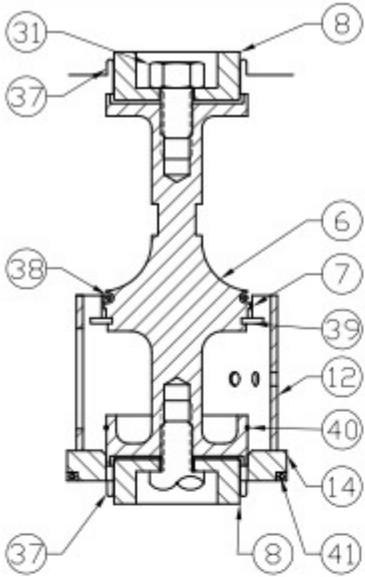

PISTON DETAIL

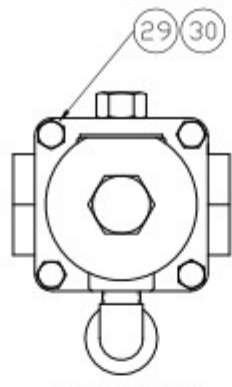

TOP VIEW

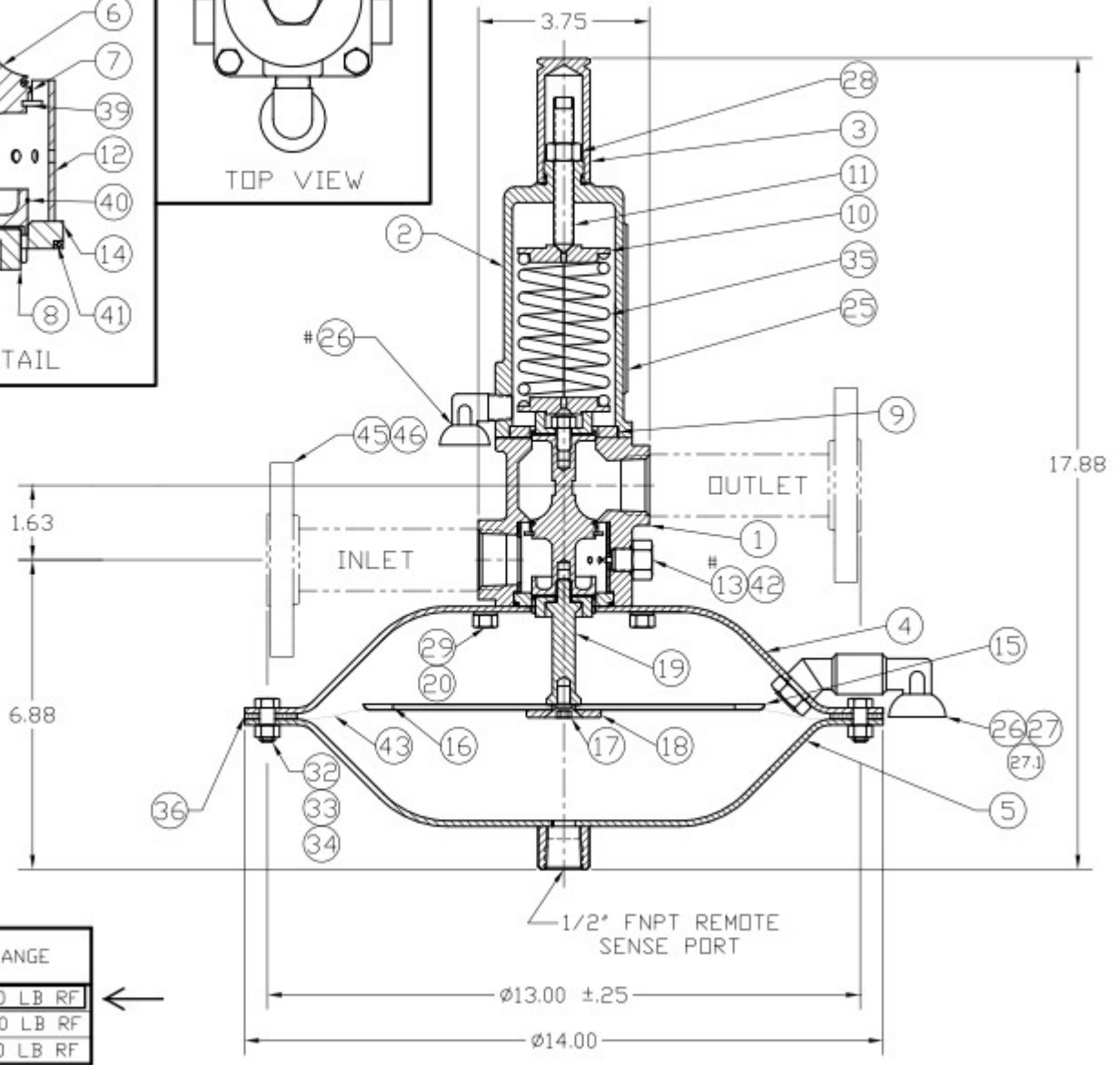

TYPE	FLANGE
STANDARD	1"-150 LB RF
OPTIONAL	2"-150 LB RF
OPTIONAL	1"-300 LB RF

ITEM	DESCRIPTION	STANDARD MATERIALS OF CONSTRUCTION	OPTIONAL FEATURES
		316 SS	<input type="checkbox"/>
1	BODY	CF-8M (316 SS)	
2	BONNET, SPRING	CF-8M (316 SS)	
3	CAP, ADJ SCREW	303 SS	
4	HOUSING, ACTUATOR- UPPER	316 SS	
5	HOUSING, ACTUATOR- LOWER	316 SS	
6	PISTON	316 SS	
7	RETAINER, O-RING- PISTON SEAT	316 SS	
8	RETAINER, DIAPHRAGM- LOWER	316 SS	
9	ADAPTER, BONNET	316 SS	
10	BUTTON, SPRING	316 SS	
11	SCREW, ADJUSTMENT	316 SS	
12	SLEEVE, ORIFICE SELECTOR	304 SS	
13	SCREW, LOCKING- SLEEVE	316 SS	
14	RING, GUIDE- PISTON	316 SS	
15	PLATE, SUPPORT	316 SS	
16	PLATE, DIAPHRAGM BACKUP	316 SS	
17	SCREW, SOCKET CAP	SS	
18	WASHER, SUPPORT PLATE	316 SS	
19	PISTON, LOWER PIN	316 SS	
20	WASHER, FLAT	SS	
25	NAMEPLATE	316 SS	
26	VENT, BONNET	ALUMINUM	
27	VENT, BREATHER/BUG	ALUMINUM	
27.1	COUPLING, FULL	316 SS	
28	NUT, HEX	316 SS	
29	BOLT, HEX	SS	
30	WASHER, LOCK	SS	
31	BOLT, HEX	SS	
32	BOLT, HEX	SS	
33	WASHER, LOCK	SS	
34	NUT, HEX	SS	
35	SPRING	316 SS	
36	* GASKET, ACTUATOR (1)	TEFLON® FEP	
37	* DIAPHRAGM, PISTON (2)	chemraz	
38	* O-RING, PISTON (2)	chemraz	
39	RING, RETAINING	SS	
40	STOP, LIFT	316 SS	
41	* O-RING, GUIDE RING (2)	chemraz	
42	* O-RING, LOCKING SCREW (2)	chemraz	
43	* DIAPHRAGM, ACTUATOR (1)	TEFLON® FEP	
45	NIPPLE, PIPE (3)	316 SS	
46	FLANGE, RF (3)	316 SS	

MODEL 3041HP
BLANKET GAS REGULATOR
VACUUM SERVICE

SEE TOP VIEW FOR ORIENTATION
* ALIGN WITH ITEM #26

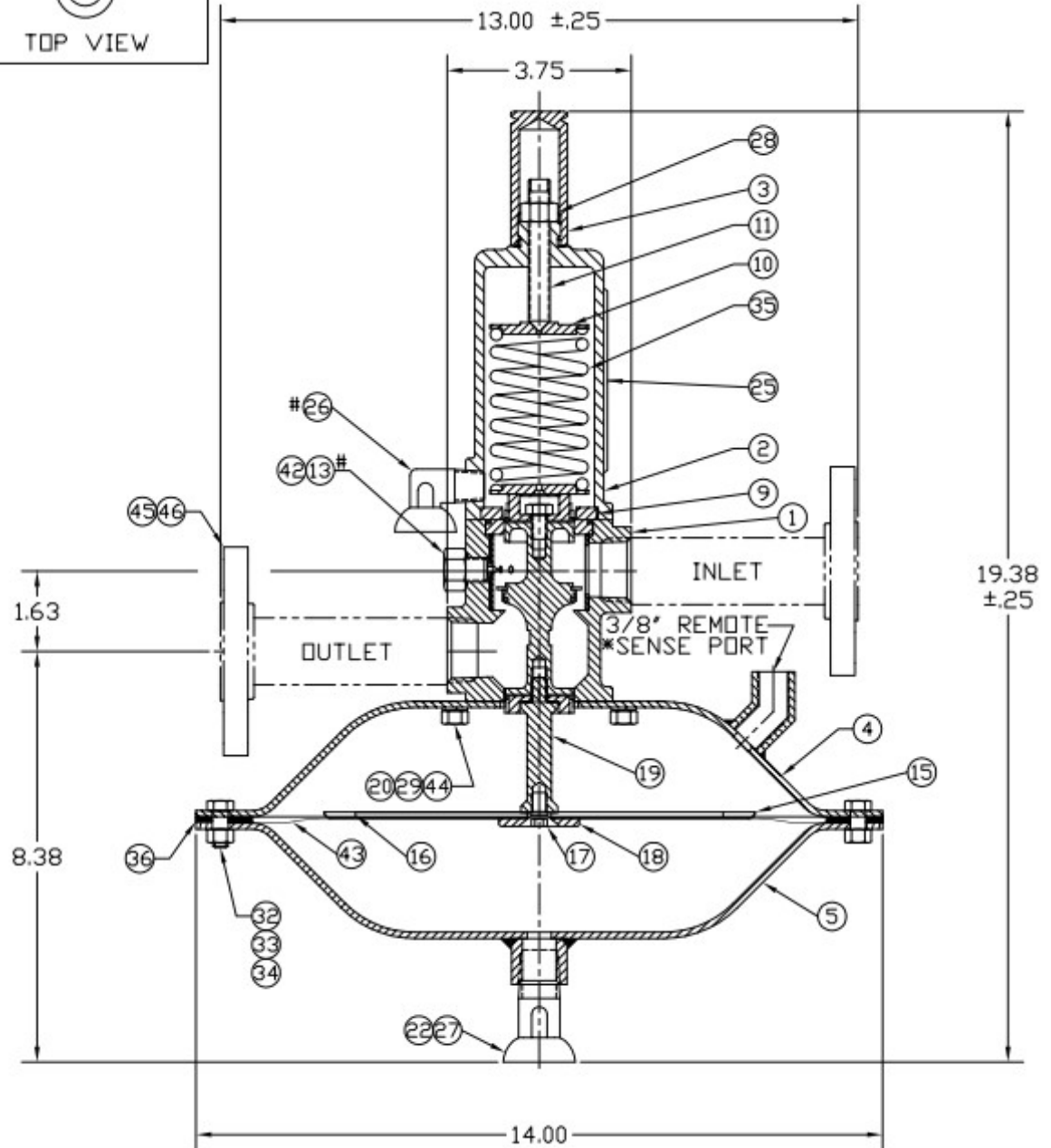
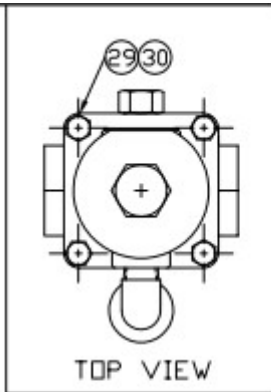
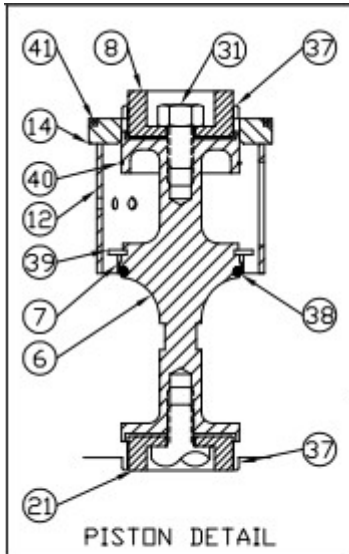

TYPE	FLANGE
STANDARD	1'-150 LB RF
OPTIONAL	2'-150 LB RF
OPTIONAL	1'-300 LB RF







MODEL 3041HP

BILL OF MATERIAL

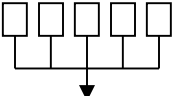
ITEM	DESCRIPTION	STANDARD MATERIALS OF CONSTRUCTION	OPTIONAL FEATURES
		316 SS	
1	BODY	CF-8M (316 SS)	
2	BONNET, SPRING	CF-8M (316 SS)	
3	CAP, ADJ SCREW	303 SS	
4	HOUSING, ACTUATOR- UPPER	316 SS	
5	HOUSING, ACTUATOR- LOWER	316 SS	
6	PISTON	316 SS	
7	RETAINER, O-RING- PISTON SEAT	316 SS	
8	RETAINER, DIAPHRAGM- LOWER	316 SS	
9	ADAPTER, BONNET	316 SS	
10	BUTTON, SPRING	316 SS	
11	SCREW, ADJUSTMENT	316 SS	
12	SLEEVE, ORIFICE SELECTOR	304 SS	
13	SCREW, LOCKING- SLEEVE	316 SS	
14	RING, GUIDE- PISTON	316 SS	
15	PLATE, SUPPORT	316 SS	
16	PLATE, DIAPHRAGM BACKUP	316 SS	
17	SCREW, SOCKET CAP	SS	
18	WASHER, SUPPORT PLATE	316 SS	
19	PISTON, LOWER PIN	316 SS	
20	WASHER, FLAT	SS	
21	RETAINER, DIAPHRAGM-UPPER	316 SS	
22	BUSHING, REDUCING	316 SS	
25	NAMEPLATE	316 SS	
26	VENT, BONNET	ALUMINUM	
27	VENT, BREATHER/BUG	ALUMINUM	
28	NUT, HEX	316 SS	
29	BOLT, HEX	SS	
30	WASHER, LOCK	SS	
31	BOLT, HEX	SS	
32	BOLT, HEX	SS	
33	WASHER, LOCK	SS	
34	NUT, HEX	SS	
35	SPRING	316 SS	
36	* GASKET, ACTUATOR (1)	FLUOROPOLYMER	
37	* DIAPHRAGM, PISTON (2)	BUNA-N	
38	* O-RING, PISTON (2)	BUNA-N	
39	RING, RETAINING	SS	
40	STOP, LIFT	316 SS	
41	* O-RING, GUIDE RING (2)	BUNA-N	
42	* O-RING, LOCKING SCREW (2)	BUNA-N	
43	* DIAPHRAGM, ACTUATOR (1)	FLUOROPOLYMER	
44	* O-RING, BRACKET (2)	BUNA-N	
45	NIPPLE, PIPE (3)	316 SS	
46	FLANGE, RF (3)	316 SS	

The nameplate on the Groth Model 3011L and 3011H Tank Blanketing Regulator contains the model number, serial number, set pressure & range and supply pressure. The model number contains additional information about material of construction, capacity and options. The following chart will assist in relating the model number to the specifications of your regulator:

HOW TO ORDER

MODEL #	INLET OUTLET	MATERIAL	SOFT GOODS	ORIFICE POSITION	SPRING RANGE	OPTIONS
 <p>3011L 3011H 3041L 3041H 3011HPF = DN15 PN 10/16 DIN RF FLANGE 3041HP</p>	 <p>A = 1" 150# ANSI RF FLANGE E = 1/2" 150# ANSI RF FLANGE N = 1" NPT O = 1/2" NPT C = DN25 PN 10/16 DIN RF FLANGE S = 1/2" SANITARY CONNECTIONS Q = 1/2" QUICK COUPLINGS</p>	 <p>5 = 316 SS</p>	 <p>B = BUNA-N E = EPDM V = FKM Z = SPECIAL C = FFKM</p>	 <p>1 = 100% 2 = 75% 3 = 50% 4 = 25% 5 = 20%* 6 = 15%* 7 = 10%* 8 = 5%*</p>	 <p>SELECT FROM SPRING SELECTION TABLE (PAGE 6)</p>	 <p>0 = NONE Z = SPECIAL OPTIONS</p>

* NOT OPTIONAL FOR 1/2" SIZE

EXAMPLE 3 0 1 1 H - N - 5 - V - 1 - 2 - 0

Indicates a model 3011H regulator 1" size with 1" NPT body connections, 316 SS construction, FKM elastomers, full capacity orifice, set pressure range from 1.0" WC to 1.5" WC and no special options.

A "Z" in the model number indicates a non-standard material or feature. Review your purchase specifications or consult Groth Corporation for more details.

PRODUCT LIMITED WARRANTY

Only Groth's Product Limited Warranty terms apply to purchase orders accepted by Groth Corporation.

- A. Seller warrants that products that are manufactured by Seller are manufactured in accordance with published specifications and free from defects in materials and/or workmanship for a period of (12) twelve months. Seller, at its option, will repair or replace any products returned intact to the factory, transportation charges prepaid, which Seller, upon inspection, determines to be defective in material and/or workmanship. The foregoing shall constitute the sole remedy for any breach of Seller's warranty.
- B. THERE ARE NO UNDERSTANDINGS, AGREEMENTS, REPRESENTATIONS, OR WARRANTIES, EXPRESS OR IMPLIED (INCLUDING MERCHANTABILITY OR FITNESS FOR A PARTICULAR PURPOSE REGARDING PRODUCTS) UNLESS SPECIFIED IN THE SALES CONTRACT. THIS CONTRACT STATES THE ENTIRE OBLIGATION OF SELLER. Seller makes no warranties, either express or implied, except as provided herein, including without limitation thereof, warranties as to marketability, merchantability, for a particular purpose or use, or against infringement of any patent of products. In no event shall Seller be liable for any direct, incidental or consequential damages of any nature, or losses or expenses resulting from any defective new product or the use of any such product, including any damages for loss of time, inconvenience, or loss of use of any such product.
- C. The original Manufacturer shall be solely responsible for the design, development, supply, production, and performance of its products hereunder, and the protection of its trade name or names, if any. It assumes no responsibility, for products modified or changed by its agent or customer, or any other third party. Any such modifications or changes to products sold by Seller hereunder shall make the product limited warranty null and void.
- D. Groth assumes no responsibility for products modified or changed by Customer or any other third party. Any such modifications or changes to products sold by Groth hereunder shall make the product limited warranty null and void. Groth shall be under no obligation to manufacture, sell or supply, or to continue to manufacture, sell, or supply any of the products.